

STATE OF TEXAS
COUNTY OF HARRIS

We, Meta Shelter Capital LLC, a Texas Limited Liability Company, acting by and through, Oluwole Sotunde and Shakiudeen Shakioye, being officers of Meta Shelter Capital LLC, hereinafter referred to as Owners (whether one or more) of the 0.11 acre tract described in the above and foregoing map of RYONS ADDITION PARTIAL REPLAT NO 2, do hereby make and establish said subdivision an development plan of said property according to all lines, dedications, restrictions, and notations on said maps or plat and hereby dedicate to the use of the public forever, all streets (except those streets designated as private streets, or permanent access easements), alleys, parks, water courses, drains, easements and public places shown thereon for the purposes and considerations therein expressed; and do hereby bind ourselves, our heirs, successors and assigns to warrant and forever defend the title on the land so dedicated.

FURTHER, Owners have dedicated and by these presents do dedicate to the use of the public for public utility purpose forever unobstructed aerial easements. The aerial easements shall extend horizontally an additional eleven feet, six inches (11' 6") for ten feet (10' 0") perimeter ground easements or seven feet, six inches (7' 6") for fourteen feet (14' 0") perimeter ground easements or five feet, six inches (5' 6") for sixteen feet (16' 0") perimeter ground easements, from a plane sixteen feet (16' 0") above the ground level upward, located adjacent to and adjoining said public utility easements that are designated with aerial easements (U.E. and A.E.) as indicated and depicted hereon, whereby the aerial easement totals twenty one feet, six inches (21' 6") in width.

FURTHER, Owners have dedicated and by these presents do dedicate to the use of the public for public utility purpose forever unobstructed aerial easements. The aerial easements shall extend horizontally an additional ten feet (10' 0") for ten feet (10' 0") back-to-back ground easements, or eight feet (8' 0") for fourteen feet (14' 0") back-to-back ground easements or seven feet (7' 0") for sixteen feet (16' 0") back-to-back ground easements, from a plane sixteen feet (16' 0") above ground level upward, located adjacent to and adjoining said public utility easements that are designated with aerial easements (U.E. and A.E.) as indicated and depicted hereon, whereby the aerial easement totals thirty feet (30' 0") in width.

FURTHER, Owners do hereby declare that all parcels of land designated as lots on this plat are originally intended for the construction of single family residential dwelling units thereon (or the placement of mobile home subdivision) and shall be restricted for same under the terms and conditions of such restrictions filed separately.

FURTHER, Owners do hereby covenant and agree that all of the property within the boundaries of this plat is hereby restricted to prevent the drainage of any septic tanks into any public or private street, permanent access easement, road or alley, or any drainage ditch, either directly or indirectly.

FURTHER, Owners do hereby dedicate to the public a strip of land fifteen feet (15' 0") wide on each side of the center line of any and all bayous, creeks, gullies, ravines, draws, sloughs or other natural drainage courses located in said plat, as easements for drainage purposes, giving the City of Houston, Harris County, or any other governmental agency, the right to enter upon said easement at any and all times for the purpose of construction and maintenance of drainage facilities and structures.

FURTHER, Owners do hereby covenant and agree that all of the property within the boundaries of this plat and adjacent to any drainage easement, ditch, gully, creek or natural drainage way shall hereby be restricted to keep such drainage ways and easements clear of fences, buildings, planting and other obstructions to the operations and maintenance of the drainage facility and that such abutting property shall not be permitted to drain directly into this easement except by means of an approved drainage structure.

FURTHER, Owners do hereby certify that this amending plat does not attempt to alter, amend, or remove any covenants or restrictions.

IN TESTIMONY WHEREOF Meta Shelter Capital LLC, a Texas Limited Liability Company, has caused these presents to be signed by Oluwole Sotunde and Shakiudeen Shakioye, officers, thereunto authorized this

____ day of ____ 202__.

Meta Shelter Capital LLC a Texas Limited Liability Company

By: _____
Oluwole Sotunde

By: _____
Shakiudeen Shakioye

STATE OF TEXAS
COUNTY OF HARRIS

BEFORE ME, the undersigned authority, on this day personally appeared Oluwole Sotunde and Shakiudeen Shakioye, known to me to be the person whose name is subscribed to the foregoing instrument and acknowledged to me that he executed the same for the purposes and considerations therein expressed.

GIVEN UNDER MY HAND AND SEAL OF OFFICE, this ____ day of ____ 202__.

Notary Public in and for the State of Texas

Print Name: _____

My Commission expires: _____

I, David R. Strickland am registered under the laws of the State of Texas to practice the profession of surveying and hereby certify that the above subdivision is true and accurate; was prepared from an actual survey of the property made under my supervision on the ground; that, except as shown all boundary corners, angle points, points of curvature and other points of reference have been marked with iron (or other objects of a permanent nature) pipes or rods having an outside diameter of not less than five eighths (5/8) inch and a length of not less than three (3) feet; and that the plat boundary corners have been tied to the Texas Coordinate System of 1983, south central zone.



Texas Registration No. 5124

PARKS AND OPEN SPACE TABLE	
Number of Existing Dwelling Units	0
Number of Proposed Dwelling Units	2
Number of Incremental Dwelling Units	2

DWELLING UNIT DENSITY TABLE		
COLUMN A	COLUMN B	COLUMN C
TOTAL NO. OF DWELLINGS	TOTAL GROSS ACREAGE (AC)	TOTAL PROJECT DENSITY
2	0.11	18.18

TYPICAL LOT LAYOUT

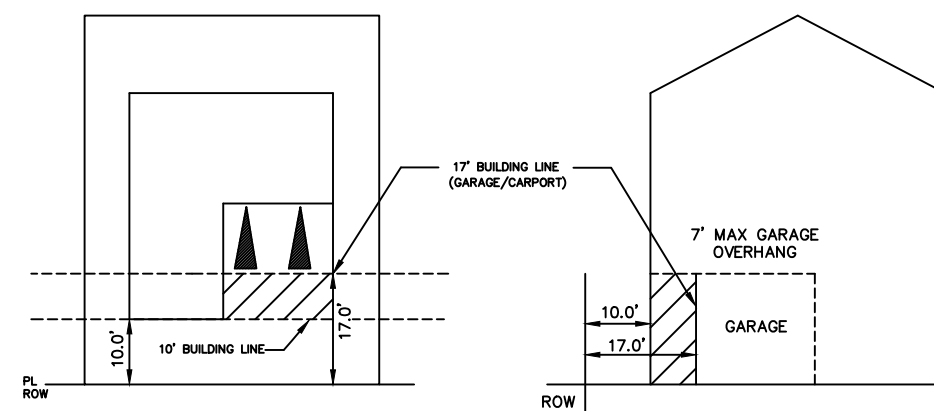

- NOTES:
1) Lots 1 - 4, Block 1 are restricted to single family residential use.
2) A 10' building line is established for the principle structure only.
3) A 17' Building line is for any carport or garage facing the street.
4) The Building shown above the carport or garage may overhang the building line up to 7 feet.
5) Reference above is a typical lot layout.

LOT SIZE AND COVERAGE TABLE (45-184(1))			
COLUMN A	COLUMN B	COLUMN C	COLUMN D
LOT NO.	LOT SIZE (SF)	MAXIMUM BLDG. COVERAGE (SF)	MAXIMUM % COVERAGE (COL. C/COL. B)
BLOCK 1			
1	2,750	1,650	60%
2	2,250	1,350	60%

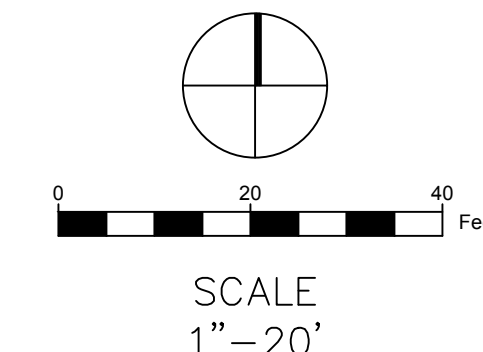

By: _____
Martha L. Stein
Chair

By: _____
M. Sonny Garza
Vice-Chairman

By: _____
Margaret Wallace Brown, AIGP,
CNU-A, Secretary

I, Tenneshia Hudspeth, County Clerk of Harris County, do hereby certify that the within instrument with its certificate of authentication was filed for registration in my office on ____ 202__, at ____ o'clock ____ M. and duly recorded on ____ 202__, at ____ o'clock ____ M., and at Film Code Number _____ of the Map Records of Harris County for said county. Witness my hand and seal of office, at Houston, the day and date last above written.

Tenneshia Hudspeth
County Clerk
Of Harris County, Texas

By: _____
Deputy

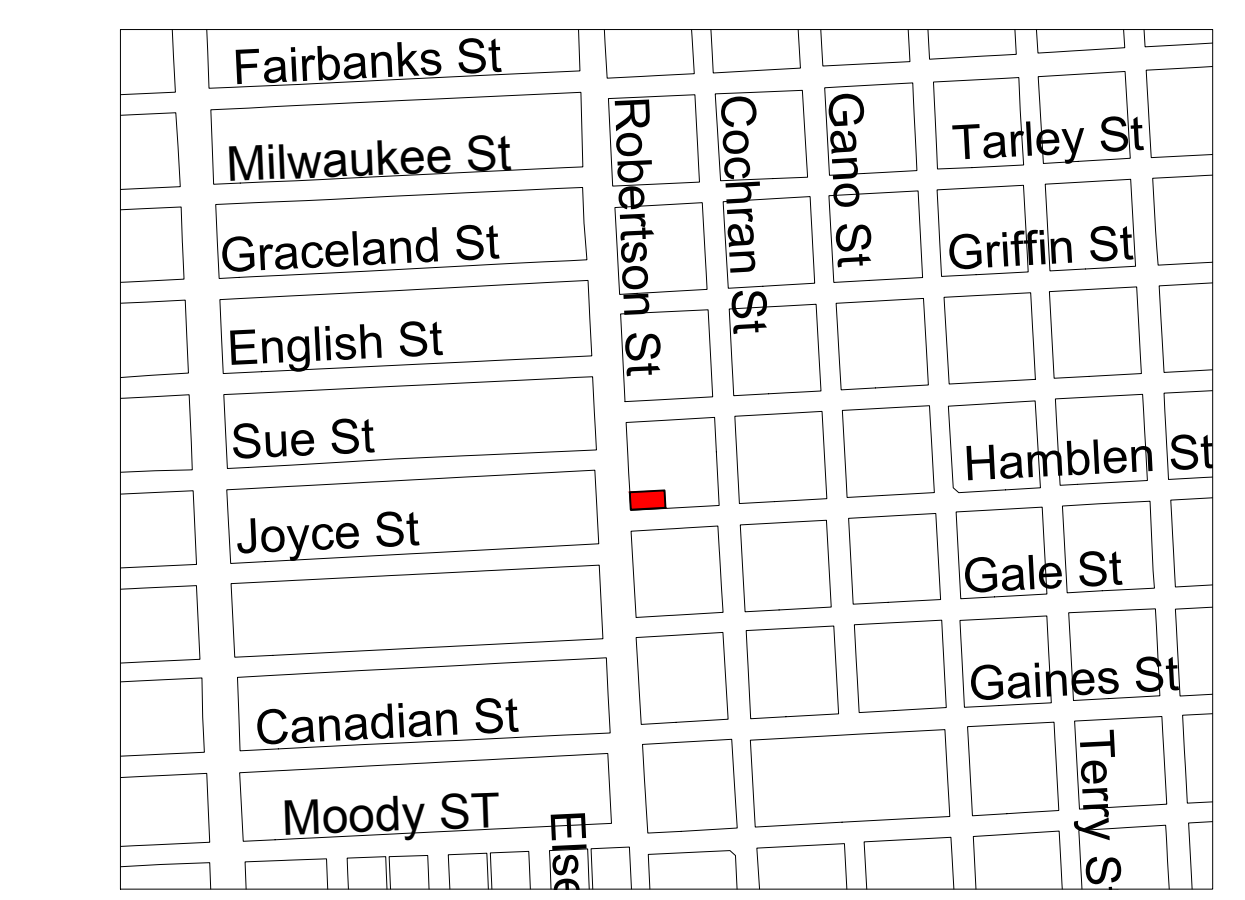
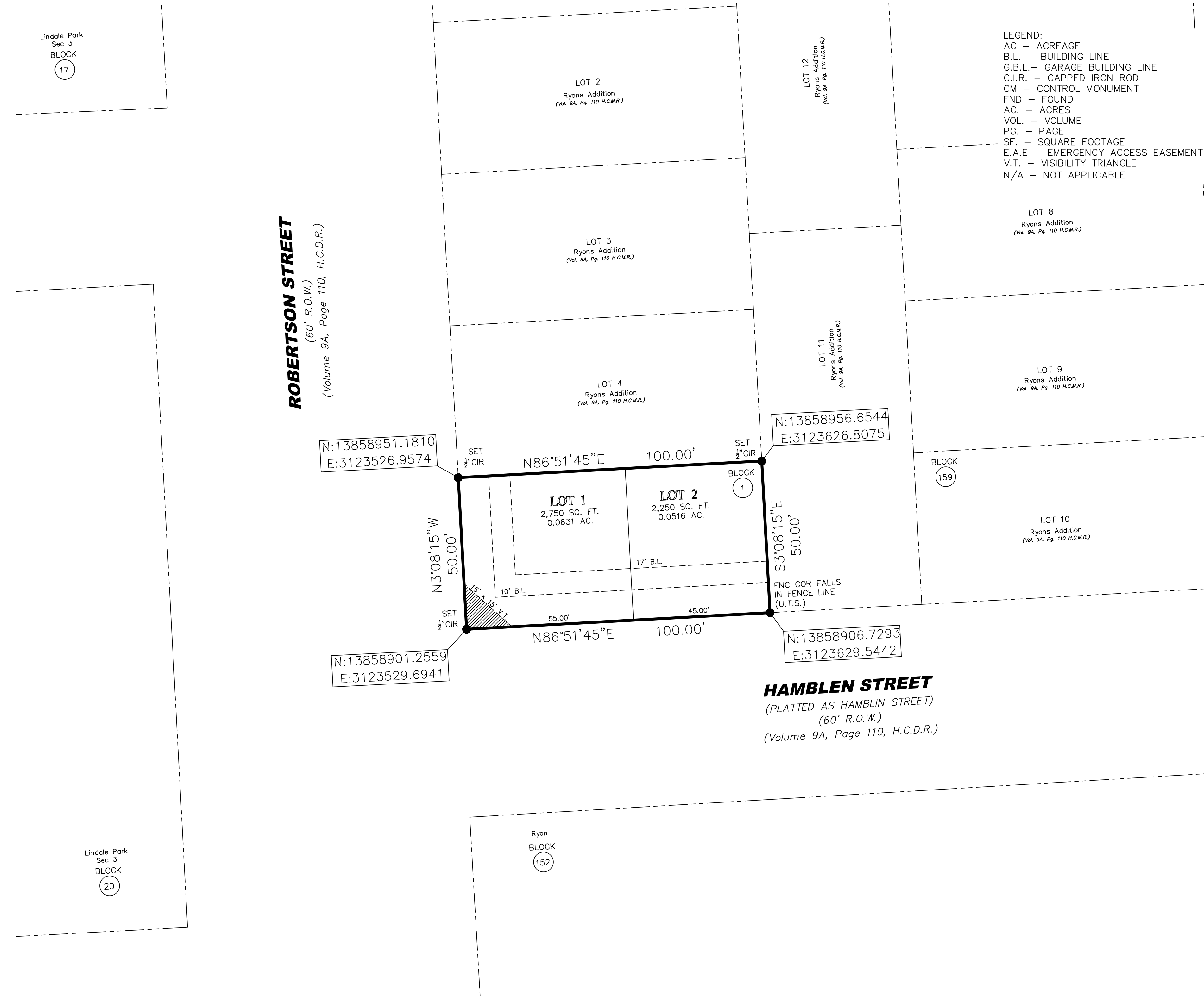

Vicinity Map not to scale KEY MAP NO. 453V

- NOTES:
- Bearings were based on the Texas State Plane Coordinate System, South Central Zone (NAD83).
 - The coordinates shown hereon are Texas South Central Zone No. 4204 State Plane Grid Coordinates (NAD 83), and may be brought to surface by applying the following scale factor 1.00000102739071
 - Unless otherwise indicated, the building lines (B.L.), whether one or more, shown on this subdivision plat are evidence of compliance with the applicable provisions of Chapter 42, Code of Ordinances, City of Houston, Texas, in effect at the time this plat was approved, which may be amended from time to time.
 - Absent written authorization by the affected utilities, all utility and aerial easements must be kept unobstructed from any non-utility improvements or obstructions by the property owner. Any unauthorized improvements or obstructions may be removed by any public utility at the property owner's expense. While wooden posts and paneled wooden fences along the perimeter and back to back easements and alongside rear lots lines are permitted, they too may be removed by public utilities at the property owner's expense should they be an obstruction. Public Utilities may put said wooden posts and paneled wooden fences back up, but generally will not replace with new fencing.
 - Single-Family Residential shall mean the use of a lot with one building designed for and containing not more than two separate units with facilities for living, sleeping, cooking, and eating therein. A lot upon which is located a free-standing building containing one dwelling unit and a detached secondary dwelling unit of not more than 900 square feet also shall be considered single-family residential. A building that contains one dwelling unit on one lot that is connected by a party wall to another building containing one dwelling unit on an adjacent lot shall be single-family residential.
 - Each lot shall provide a minimum of two off-street parking spaces per unit. In those instances where a secondary unit is provided only one additional space shall be provided.
 - This property lies within Park Sector No. 17.
 - No land is being established as Private Park or dedicated to the public for Park Purposes.
 - This percentage is (100%) shall be applied to the then-current fee in lieu of dedication.
 - The then current fee in lieu of dedication shall be applied to this number (2 units) of dwelling units.
 - No building permit or other permit, except permits for construction of public improvements, will be issued by the City of Houston, Texas, for construction within the subdivision until such time as the funds required under provisions of Section 42-253 of the Code of Ordinances of the City of Houston, Texas, has been submitted and accepted by the City.
 - Lots 1-2, Block 1 are restricted to single family residential use.
 - At least 150 square feet of permeable area is required per lot (300 sq. of permeable area shall be provided within the boundary of this subdivision. Reference 42-1 permeable area definition.
 - All lots shall have an adequate wastewater collection service.
 - The number of single family residential dwelling units that can be constructed shall not exceed an equivalent density of 27 units to the gross acre of all land within the boundaries of this subdivision plat.
 - The building line for property adjacent to two intersecting streets shall not encroach into any visibility triangle. This area shall assure adequate visibility sight lines for vehicular traffic approaching the intersection. The maximum height of the visibility triangle shall be 20 feet as measured vertically from the ground.

RYONS ADDITION PARTIAL REPLAT NO 2

A SUBDIVISION OF 0.11 ACRES OF LAND BEING A REPLAT OF LOT 5 BLOCK 159 OF RYONS ADDITION, ACCORDING TO THE PLAT OR MAP THEREOF RECORDED IN VOLUME 9A PAGE 110, OF MAP RECORDS OF HARRIS COUNTY, TEXAS HOUSTON, TEXAS

REASON FOR REPLAT: TO CREATE 2 (TWO) SINGLE-FAMILY RESIDENTIAL LOTS

DATE: APRIL, 2021 SCALE: 1" = 20'
LOTS: 2 BLOCKS: 1

LAND PLANNER: **CGES | BAILEY PLANNING**
2016 MAIN STREET HOUSTON, TEXAS 77002
O:713.965.7385
E: INFO@CGESBAILEY.COM

OWNER: META SHELTER CAPITAL LLC
26023 SUMMER SAVORY LANE
KATY, TX. 77494

HABLAMOS ESPAÑOL